

Development of Smart Helmet Detection System for Motorcycle Rider

Dr.D.R.P. Rajarathnam¹, S. Manikandan², S. Gokul³, G. Viknesh⁴, S. Ranjith⁵

¹Professor, Department of Mechatronics, Paavai Engineering College, Pachal, Namakkal, India.

²Assistant Professor, Department of Mechatronics, Paavai Engineering College, Pachal, Namakkal, India.

^{3,4,5}UG Scholar, Department of Mechatronics, Paavai Engineering College, Pachal, Namakkal, India.

Emails: drpprajamalathi@gmail.com¹, manibeqc@gmail.com², gokulkrishna24pks@gmail.com³, vikneshviknesh255@gmail.com⁴, ranjith200314@gmail.com⁵

Abstract

Street wellbeing is a central issue, especially with issues like cap resistance and liquor utilization, the two of which essentially increment the gamble of mishaps and fatalities. Head wounds, frequently brought about by not wearing protective caps, are a main source of death and handicap in street occurrences. Moreover, liquor utilization weakens basic mental capabilities, for example, independent direction and response time, which are fundamental for safe driving. This issue is particularly serious in high-traffic regions like India, where plastered driving can make mishaps significantly more hazardous. To handle these issues, we propose a brilliant protective cap framework that incorporates both a gas sensor and a head protector sensor to guarantee security. The gas sensor identifies the driver's liquor levels, while the head protector sensor checks whether the driver is wearing a cap. On the off chance that the cap isn't worn, or on the other hand assuming liquor is identified in the driver's framework, the vehicle's key will be locked, forestalling start. This action guarantees that drivers can't work their vehicle under perilous circumstances. Moreover, on the off chance that liquor is recognized after the key is opened, the framework will send a GSM message to the driver's family, cautioning them of the risky condition. By coordinating innovation with head protector consistence and liquor location, this shrewd cap framework means to altogether decrease mishap rates, advance dependable driving, and upgrade generally street security. The framework's constant correspondence and observing capacities assume an essential part in further developing driver conduct and decreasing the gamble of lethal mishaps out and about.

Keywords: Gas Sensor, GSM message, Resistance and Liquor levels.

1. Introduction

Street security is a basic issue around the world, with head protector resistance and liquor utilization among drivers contributing fundamentally to car crashes and fatalities. Consistently, a huge number of individuals are harmed or killed on streets because of preventable factors, for example, the inability to wear head protectors or driving affected by liquor. Head wounds, which are in many cases the consequence of not wearing a cap, are among the main sources of death and extremely durable handicap in street mishaps. Caps are intended to safeguard the head by diminishing the effect of a

crash, forestalling skull cracks and mind wounds [1]. Notwithstanding the known advantages of protective caps, numerous drivers, especially those riding bikes or bikes, neglect to utilize them reliably, particularly in nations where cap authorization is remiss. This inability to wear protective caps adds to a significant number of street passing's every year. Liquor utilization further compounds this issue by hindering a driver's mental capacities, response time, and direction [2]. Liquor influences the cerebrum's capacity to handle data rapidly, lessens sharpness, and twists judgment, which are all basic for driving.

Drivers affected by liquor are bound to pursue unfortunate choices, for example, speeding, disregarding traffic lights, or neglecting to see different vehicles or walkers, which emphatically improves the probability of mishaps. In thickly populated, high-traffic conditions like India, tanked driving is a serious worry that prompts numerous deadly mishaps. When joined with cap rebelliousness, the risks out and about duplicate, prompting higher paces of mishaps, wounds, and fatalities. With an end goal to handle these critical issues, we propose a savvy head protector framework that coordinates various innovations to further develop street security [3]. This framework is intended to guarantee that drivers stick to somewhere safe and secure conventions, explicitly head protector use and liquor utilization limits. The savvy head protector is outfitted with a gas sensor to recognize liquor levels in the driver's breath, as well as a cap sensor to check in the event that the driver is wearing a cap. In the event that the protective cap sensor recognizes that the driver isn't wearing a head protector, or on the other hand assuming the gas sensor identifies dangerous liquor levels, the framework makes a prompt move [4]. It locks the vehicle's start key, keeping the vehicle from beginning. This preventive measure guarantees that drivers can't work the vehicle under dangerous circumstances, for example, being affected by liquor or not wearing a cap. The framework likewise sends a GSM message to the driver's family on the off chance that liquor is distinguished, making them aware of the perilous circumstance. This additional layer of correspondence gives families continuous updates on the driver's condition and wellbeing, permitting them to intercede if essential. consolidating trend setting innovation with constant correspondence and checking, this brilliant cap framework intends to fundamentally diminish the quantity of street mishaps brought about by cap resistance and liquor utilization. The shrewd protective cap framework offers a thorough answer for the continuous issues of street wellbeing. By guaranteeing protective cap use, identifying liquor utilization, and giving ongoing criticism, this framework can assume an essential part in decreasing street mishaps, advancing mindful

driving, and at last saving lives [5]. As street security stays a worldwide concern, coordinating such advances into day to day driving practices could have a huge effect in forestalling traffic-related wounds and fatalities, adding to more secure streets for all.

2. Literature Survey

1. Marek Fedor et al Proposed "Fluffy Model Improvement for A Constant Powerful Discovery Framework", IEEE 2022

In this current procedure is applied in the fluffy model plan for a three-stage enlistment engine which addresses a higher request nonlinear framework. Reproduction estimations in MATLAB affirmed the precision, viability and great powerful properties of the proposed fluffy model and furthermore its appropriateness to consistent unique frameworks with as minimal past information as could be expected [6]. The point of the article is to demonstrate the way that the mechanized fluffy displaying methods can be utilized likewise to get an exact fluffy model of a low intricacy in view of a bunch of series of estimations.

2. Subham Sahoo et al Proposed "On The Logic of Discovery Information Driven Regulators for Power Electronic Converters", IEEE 2022

They have fostered the activities of the black box models by working out a contingent entropy for each contribution regarding a result [7]. Utilizing this measurement, the found the middle value of connections between each information result can be planned and delegate ends are first and foremost drawn on distinguishing mistaken information. At long last, this strange information is then eliminated from the preparation data set to work on the interpretability and order capacities of the ML model. We delineate our discoveries on the exhibition of a relapse-based learning instrument utilized for controlling a framework associated voltage source inverter (VSI).

3. Khamdamov Rustam Khamdamovich et al Proposed "Procedures and Techniques for Black Box Recognizing Weaknesses in Web Servers", IEEE.2021

They have dissected the meaning of weakness in a web server utilizing the black box strategy. The article shows the principal issues of filtering web

applications [8]. The BLACK BOX procedure that characterizes weaknesses in web waiters is examined: identicalness classes, limit values, choice table, pairwise testing, state progress outline, use cases.

4. Divyashree K, Likhithesh M D, Arpitha M, Madanraj K S, Raghu S, Vinay Kumar S B et al Proposed "Substitute Model Age for Discovery Ill-Disposed Assault in View of Information Distillation" IEEE.2021

The current strategy calculation distils various CNN instructor models to a minimal understudy model as the replacement of other discovery CNN models to be gone after [9]. The black-box ill-disposed examples can be thus produced on this substitute model by utilizing different white-box going after techniques. As per our analyses on ResNet18 and DenseNet121, our calculation helps the going after progress rate (ASR) by 20% via preparing the substitute model in light of information refining.

5. Karthik K S, Poonam B T, Darshan B, Benaka Santhosh et al Proposed "Discovery Demonstrating of Back-Up Short Out Tests", IEEE-2021

The current framework is to foster a minimal expense framework which gives answer for the current car control issues. This framework has two primary standard parts to be specific Vehicle to Vehicle Impact Evasion Unit (VVCAU) is utilized to try not to crash among vehicles and Discovery (BB) records the important insights concerning a vehicle, for example, Motor Temperature, Distance from snag, Speed of vehicle, CO2 Content, Liquor content, Mishap Course. The plan chooses AVR as installed regulator, UART (Widespread simultaneous Collector Transmitter) is the normal fringe found on microcontrollers broadly utilized for correspondence with the outside gadgets and frameworks, I2C (Between Incorporated Circuit) for on-board correspondence, Electrically Erasable Programmable Read Only Memory and GSM module [10].

3. Existing System

Existing street security frameworks, for example, liquor start interlock gadgets and head protector identification frameworks, work autonomously, prompting holes in implementation. Liquor start

interlocks keep vehicles from beginning assuming that liquor is distinguished, yet they are essentially utilized in vehicles and need reconciliation with head protector identification. Then again, protective cap recognition frameworks guarantee that motorcyclists wear head protectors prior to beginning their bicycles, yet they incorporate no liquor observing. While policing manual Breathalyzer tests at designated spots to stop intoxicated driving, these techniques are area explicit and not viable 100% of the time. Albeit brilliant protective caps with wellbeing observing elements are accessible, they ordinarily don't address both head protector consistence and liquor utilization together. The proposed shrewd head protector framework joins constant cap and liquor location, giving cautions and observing to make a more exhaustive way to deal with street wellbeing. This coordinated arrangement essentially improves assurance for motorcyclists and decreases mishaps brought about by resistance with security guideline [11].

4. Proposed System

The proposed framework is an imaginative shrewd cap intended to essentially upgrade street wellbeing by tending to two basic gamble factors: head protector resistance and liquor utilization among drivers. use. Assuming the cap sensor distinguishes that the protective cap isn't being worn or on the other hand in the event that the gas sensor shows dangerous liquor levels, the vehicle key will be locked, keeping the motor from turning over. Simultaneously, the vehicle light will stay off to flag this risky condition. To additional upgrade security, on the off chance that liquor is distinguished while the key is opened, a GSM ready will be shipped off the driver's family, telling them of the likely risk. This component fills in as an extra layer of responsibility and backing. In situations where neither the protective cap nor the gas sensor is enacted, the vehicle light will turn on, showing a basic wellbeing issue that needs prompt consideration. This complete methodology means to decrease mishap rates, encourage a culture of dependable driving, and at last save lives by guaranteeing that motorcyclists consent to fundamental wellbeing measures. This framework includes a gas sensor that identifies liquor levels and

a head protector sensor that guarantees legitimate cap (Figure 1).

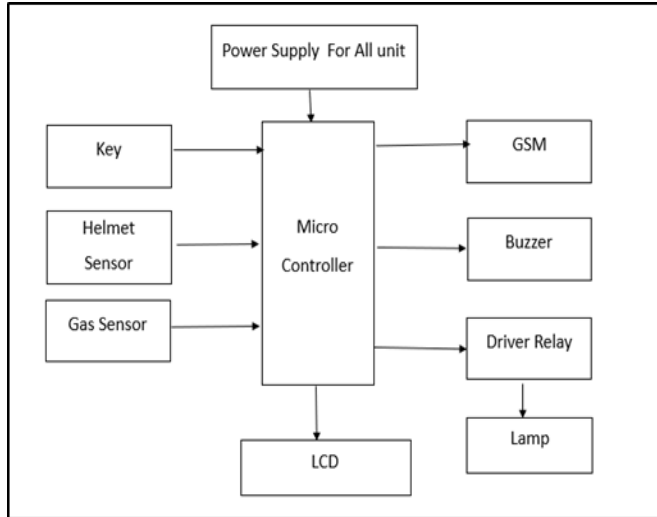

Figure 1 Block Diagram

5. Hardware & Software Description

- Power Supply
- Transformer
- Rectifier
- Smoothing
- Regulator
- Gas Sensor
- Limit Switch
- Arduino Uno
- Buzzer
- LCD
- Relay Driver
- Lamp Load
- GSM Module
- GSM Modem

6. Results & Discussion

The proposed savvy protective cap framework actually upgrades street security by tending to two significant dangers: head protector rebelliousness and liquor utilization among motorcyclists. Using a protective cap sensor to identify in the event that the head protector is worn and a gas sensor to screen liquor levels, the framework keeps the motor from turning over and keeps the vehicle light off in the event that risky circumstances are distinguished. Furthermore, in the event that liquor is distinguished when the key is opened and the head protector is

being worn, a GSM alert is shipped off the driver's family to educate them regarding the likely risk, while likewise keeping the bicycle from beginning. This coordinated methodology advances mindful driving as well as supports consistence with fundamental security measures, possibly diminishing mishaps and cultivating a culture of more secure street propensities (Figure 2).



Figure 2 GSM Alert

Conclusion

All in all, the proposed savvy head protector framework addresses a huge progression in street wellbeing by really resolving the basic issues of cap resistance and liquor utilization among drivers. By coordinating both a gas sensor and a cap sensor, the

framework guarantees that motorcyclists are safeguarded against the risks of riding without a protective cap or while affected by liquor. The locking component that forestalls vehicle start under hazardous circumstances, joined with constant cautions to relatives, improves responsibility and energizes dependable driving way of behaving. This thorough methodology intends to lessen mishap rates as well as cultivates a culture of security and obligation among riders. At last, by utilizing innovation to make a safer riding experience, this shrewd head protector framework can possibly save lives, lessen wounds, and make our streets more secure for everybody. As street wellbeing keeps on being a squeezing concern, creative arrangements like this are fundamental for advancing more secure driving practices and guaranteeing a more secure climate for all street clients.

References

- [1].Dr.C. Gangaiah Yadav, V. Jahnavi, Dillikumari, M. Geethanjali, R. Gnana Prasanna “Alcohol Detection Using Smart Helmet System”- International Journal of Creative Research Thoughts (IJCRT)-2023.
- [2].Guntupalli Sireesha, K. Baby Satya Jahnav, Anusha N, Ayusha Baburay “Smart Helmet using IoT”- International Journal of Engineering Research & Technology (IJERT)-2022.
- [3].Anjali Baburaj, Thasni V.T, Reshma N.S, Yadhu Krishnan P, Deepak K.N “Intelligent Smart Helmet System”- International Journal of Advanced Research in Computer and Communication Engineering-2020.
- [4].Israel Campero-Jurado, Sergio Márquez-Sánchez, Sara Rodríguez and Juan M. Corchado “Smart Helmet 5.0 for Industrial Internet of Things Using Artificial Intelligence”- MDPI stays neutral with regard to jurisdictional claims in published maps and institutional affiliations.
- [5].Yosoon Choi, and Yeanjae Kim “Applications of Smart Helmet in Applied Sciences: A Systematic Review”- MDPI stays neutral with regard to jurisdictional claims in published maps and institutional affiliations.
- [6].Ajith R, Sharan, Prajwal B L Shreyas, Navya Shree “A Survey on Helmet Detection and Number Plate Recognition for Safety and Surveillance System”- International Research Journal of Modernization in Engineering Technology and Science.
- [7].Dr. M. Kiran Kumar, Aniruddha Balbudhe, CH Sai Karthikeya “Dr. M. Kiran Kumar^{1*}, Aniruddha Balbudhe², CH Sai Karthikeya²”- E3S Web of Conferences 391,01149(2023) ICMED-ICMPC 2023.
- [8].Vaishali, Ashwin Shenoy M, Krishnaraj Rao N. S, Pranam R Betrabet “Helmet Detection using Machine Learning Approach”- 2022 3rd International Conference on Smart Electronics and Communication (ICOSEC).
- [9].Mohd Khairul Afiq Mohd Rasli, Nina Korlina Madzhi, Juliana Johari “Smart Helmet with Sensors for Accident Prevention”- 2013 International Conference on Electrical, Electronics and System Engineering.
- [10].Santhakumar G, Levin A., Ramkumar B. “Smart Helmet for Vehicles using IoT for Accident Avoidance”- 2023 2nd International Conference on Applied Artificial Intelligence and Computing.
- [11].Sharan L, Chandrakala GR “IoT-Enabled Smart Helmet For Enhanced Safety In Riding And Mining Environments”- International Research Journal of Modernization in Engineering Technology and Science.